

Features

- Locks all doors on body side with one padlock per side. Padlock not included.
- MLS design is two-part rod assembly for installation instructions (see Bulletin P2127)
- Spring-assist is standard (spring is detachable), and provides smooth operation with low efforts
- Strength of locking system increased more than 50%, providing additional compartment security
- This applies to all service bodies built after **Serial # B-----**

DELETE PART #	DESCRIPTION	APPLICATION
DELMLS	Removes MLS from service body	All service body models

Any service bodies that have raised front compartment, will have master locking system that extends through raised front compartment as well.

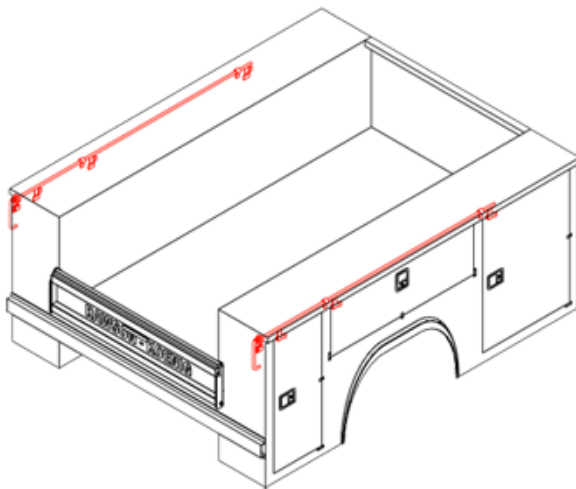

Drawing shows MLS installed
Delete part # will remove this option.

**Bodies prior to S/N# A35435 will require some modifications to the door panel to work with this new MLS system. Please consult RKI for further details.